

# THROTTLE GEAR FOR MAN E2876LE202/212/302

## INSTALLATION INSTRUCTION

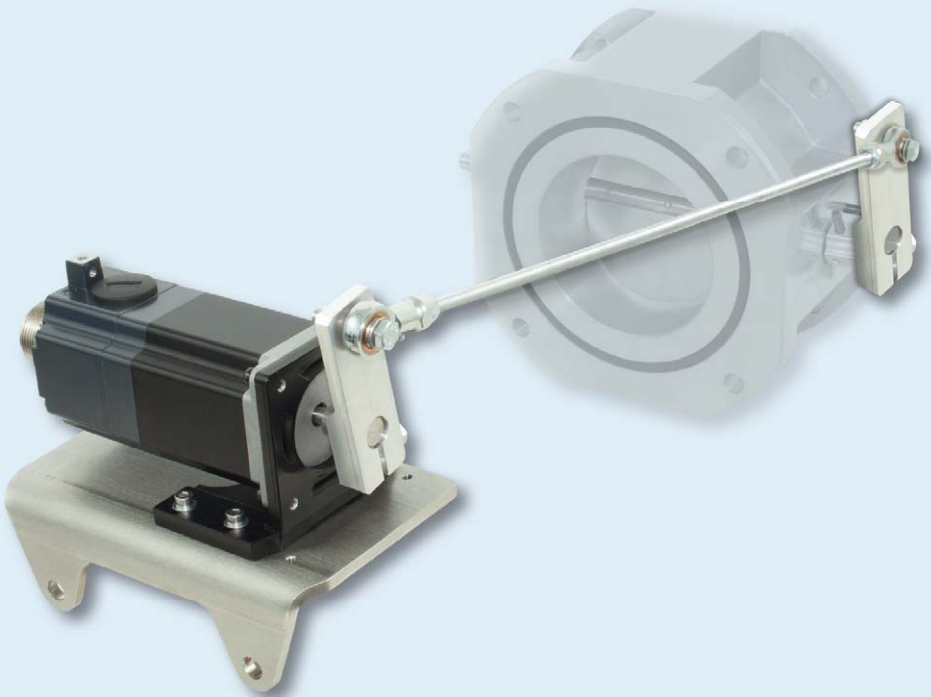

### Copyright

© Copyright 2015 MOTORTECH GmbH. All rights reserved.

Distribution and reproduction of this publication or parts thereof, regardless of the specific purpose and form, are not permissible without express written approval by MOTORTECH. Information contained in this publication may be changed without prior notice.

### Trademarks

MOTORTECH products and the MOTORTECH logo are registered and/or common law trademarks of MOTORTECH Holding GmbH. All other trademarks and logos displayed or used in this publication are the property of the respective entitled person.

# TABLE OF CONTENTS

<b>1 General Information</b> .....	<b>4</b>
1.1 What Is the Purpose of this Installation Instruction? .....	4
1.2 Who Is this Installation Instruction Targeted to?.....	4
1.3 What Symbols Are Used in the Installation Instruction? .....	5
<b>2 Safety Instructions</b> .....	<b>6</b>
2.1 General Safety Instructions .....	6
2.2 Special Safety Instructions .....	7
2.3 Proper Disposal.....	8
<b>3 Intended Use</b> .....	<b>9</b>
3.1 Functional Description .....	9
3.2 Applications.....	9
<b>4 Product Description</b> .....	<b>10</b>
4.1 Technical Data .....	10
4.2 Overview Drawings .....	10
<b>5 Installation</b> .....	<b>11</b>
5.1 Unpacking .....	11
5.2 Installing the Stepper Motor on the Engine.....	12
5.3 Wiring the Stepper Motor .....	13
5.4 Installing the Operating Lever on the Throttle .....	14
5.5 Aligning and Connecting the Operating Lever .....	15
<b>6 Start-Up</b> .....	<b>17</b>
<b>7 Errors</b> .....	<b>19</b>
<b>8 Maintenance</b> .....	<b>20</b>
8.1 Customer Service Information .....	20
8.2 Returning Equipment for Repair / Inspection .....	20
8.3 Instructions for Packaging the Equipment .....	20
8.4 Spare Parts and Accessories .....	20

# 1 GENERAL INFORMATION

Prior to use, read this Installation Instruction carefully and familiarize yourself with the product. Installation and start-up should not be carried out before reading and understanding this document. Keep this Installation Instruction readily available so that you can reference it as needed.

## 1.1 What Is the Purpose of this Installation Instruction?

This Installation Instruction serves as an aid for the installation and operation of the product and supports the technical staff with all operating and maintenance tasks to be performed. Furthermore, this manual is aimed at preventing dangers to life and health of the user and third parties.

## 1.2 Who Is this Installation Instruction Targeted to?

This Installation Instruction provides a code of conduct for personnel tasked with the set-up, operation, maintenance, and repair of stationary engines. A certain level of technical knowledge with respect to the operation of stationary engines and basic knowledge of the electronic components used are necessary. Persons who are merely authorized to operate the stationary engine are to be trained by the operating company and explicitly informed of the potential hazards.

### 1.3 What Symbols Are Used in the Installation Instruction?

The following symbols are used in this manual and must be observed:



#### **Example**

This symbol indicates examples, which point out necessary handling steps and techniques. In addition, you receive additional information from the examples, which will increase your knowledge.



#### **Notice**

This symbol indicates important notices for the user. Follow these. In addition, this symbol is used for overviews that give you a summary of the necessary work steps.



#### **Warning**

This symbol indicates warnings for possible risks of property damage or risks to health. Read these warning notices carefully and take the mentioned precautionary measures.



#### **Danger**

This symbol indicates warnings for danger to life, especially due to high voltage. Read these warning notices carefully and take the mentioned precautionary measures.

## 2 SAFETY INSTRUCTIONS

### 2.1 General Safety Instructions

MOTORTECH equipment is manufactured as state of the art and therefore safe and reliable to operate. Nevertheless the equipment can cause risks or damages can occur, if the following instructions are not complied with:

- The gas engine must only be operated by trained and authorized personnel.
- Operate the equipment only within the parameters specified in the technical data.
- Use the equipment correctly and for its intended use only.
- Never apply force.
- For all work, such as installation, conversion, adaptation, maintenance, and repair, all equipment must be disconnected from the power supply and secured against unintentional restarting.
- Perform only such maintenance and repair work as is described in this operating manual, and follow the instructions given while working. For maintenance of the equipment, only use spare parts supplied by MOTORTECH. Further work must only be performed by personnel authorized by MOTORTECH. Non-compliance with the instructions will void any warranties for the proper function of the equipment as well as the responsibility for the validity of the certifications.
- Safety devices must not be dismantled or disabled.
- Avoid all activities that can impair the function of the equipment.
- Operate the equipment only while it is in proper condition.
- Investigate all changes detected while operating the gas engine or ignition system.
- Ensure compliance with all laws, directives and regulations applicable to the operation of your system, including such not expressly stated herein.
- If the system is not entirely tight and sealed, gas may escape and lead to an explosion hazard. Upon completion of all assembly works, always check the system's tightness.
- Always ensure adequate ventilation of the engine compartment.
- Ensure a safe position at the gas engine.

## 2.2 Special Safety Instructions

The device is operated on a stationary gas engine. Please follow therefore all safety instructions of the equipment manufacturers, especially with regards to sections under high voltage. All work must be performed by trained and authorized personnel only.



### **Explosion hazard!**

When the system is powered up, do not remove any connectors unless the system is not located in a potentially explosive atmosphere.



### **Risk of injury!**

Turn off the engine prior to assembly and secure it from re-starting in order to avoid damage or injury.



### **Risk of burning!**

The surfaces of the system may heat up to high temperatures.



### **Risk of injury and destruction**

The engine must be equipped with an independent emergency shutdown switch to avoid overspeed, which can cause destruction and/or injury.



### **Risk of damage**

Throttle gear, stepper motor card and engine can be damaged by improper handling. Read and understand the corresponding operating instructions prior to any work on the throttle gear, stepper motor card and engine.

## 2 SAFETY INSTRUCTIONS



### **Operational safety!**

All screws and the military style connector must be adequately tightened.

### **2.3 Proper Disposal**

After the expiration of its service life, MOTORTECH equipment can be disposed of with other commercial waste, or it may be returned to MOTORTECH. We will ensure its environmentally friendly disposal.



## 3 INTENDED USE

### 3.1 Functional Description

A stepper motor is connected to the throttle via a connecting rod. The connecting rod transfers the movement of the stepper motor to the throttle and in this way regulates the supply of the air/fuel mixture to the engine.

### 3.2 Applications

The throttle gear is suitable for the control of a MOTORTECH throttle on an engine type MAN E2876LE202, MAN E2876LE212 and MAN E2876LE302:

The stepper motor is controlled by a VariStep stepper motor card from MOTORTECH.

Any use other than the one described in the Installation Instruction shall be considered improper use and will result in the voiding of all warranties.

## 4 PRODUCT DESCRIPTION

### 4.1 Technical Data

The throttle gear has the following technical characteristics:

Feature	Value
Dimensions	See the section <i>Overview Drawings</i> on page 10
Weight (stepper motor, installation plate and operating lever of the stepper motor)	2.1 kg (4.6 lbs)
Available holding torque	Max. 1.2 Nm (0.9 lb-ft)
Rotation angle of lever	Max. $80^\circ \pm 0.1^\circ$
Power supply	Power supply provided by VariStep stepper motor card from MOTORTECH
Completely open – completely closed	160 ms (load-independent)
Connection	Military style connector
Climatic environmental conditions	-10 °C to +85 °C (-14 °F to 185 °F) max. 85 % humidity without condensation

### 4.2 Overview Drawings

Front View

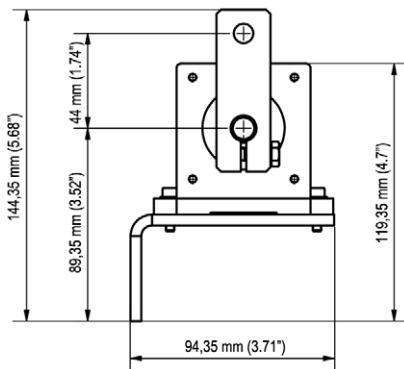

Side View

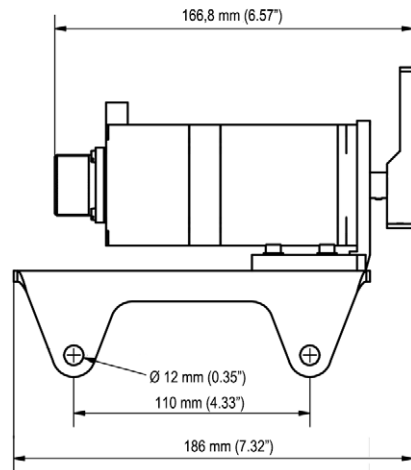

## 5 INSTALLATION

### 5.1 Unpacking

Unpack the device taking care not to damage it, and ensure that the installation instructions are always stored with the device and are easily accessible. Check the contents for completeness and verify that the device type meets your application requirements.

#### Scope of Supply

The scope of supply of the device consists of the following components:

- 1 stepper motor with bracket and operating lever
- 1 connecting rod
- 2 ball joints
- 1 operating lever for throttle
- 1 screw M8x25
- 2 nuts M8
- 2 screws M8x30
- 6 washers M8
- 1 harness 10 m
- 1 installation instruction

## 5 INSTALLATION

### 5.2 Installing the Stepper Motor on the Engine

Mount the stepper motor on the engine as follows:

1. Remove the two M12 screws marked in the drawing (see operating manual of the engine manufacturer).

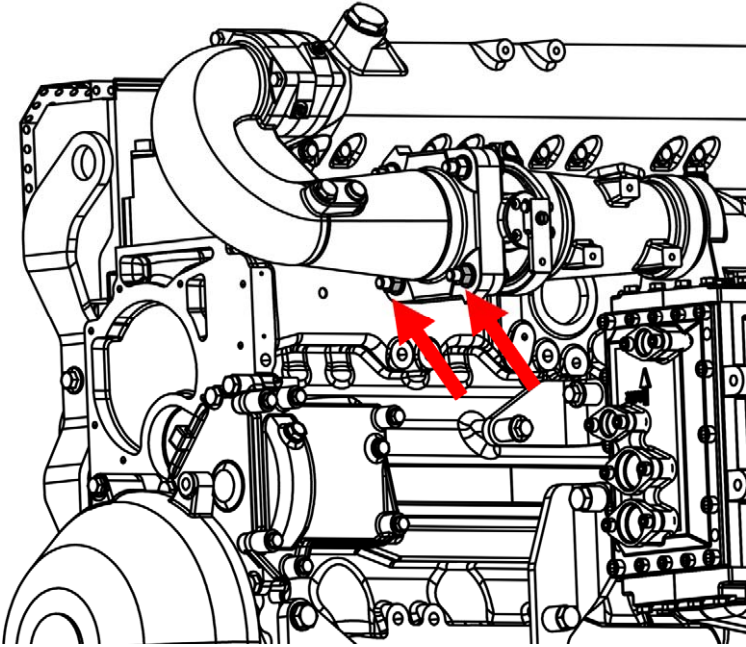

2. Attach the stepper motor to the same place with the previously removed M12 screws (torque 20 Nm / 14.8 lb-ft).

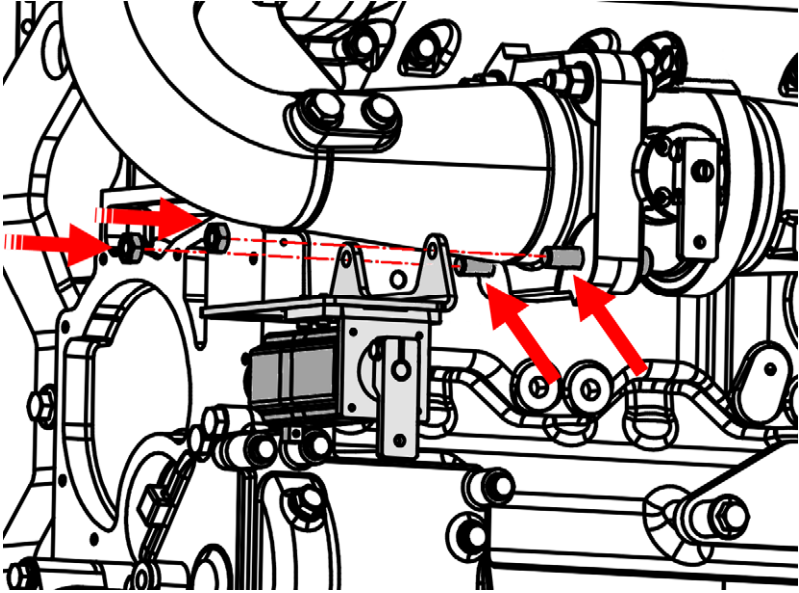

- ▶ You can wire the stepper motor (see section *Wiring the Stepper Motor* on page 13).

### 5.3 Wiring the Stepper Motor

Connect the VariStep stepper motor card from MOTORTECH as follows to the stepper motor:

1. Separate the stepper motor card from the supply voltage.
2. The stepper motor card is switched off.
3. Screw the military style connector of the harness to the stepper motor.
4. Connect the open end of the harness to the VariStep stepper motor card from MOTORTECH (see operating manual of VariStep stepper motor card).
  - ▶ Stepper motor card and stepper motor are connected via the harness.

## 5 INSTALLATION

### 5.4 Installing the Operating Lever on the Throttle

The throttle gear is not operated with the pre-installed operating lever. Install the MOTORTECH operating lever:

1. Remove the pre-installed operating lever.
2. Attach the MOTORTECH operating lever to the same place.

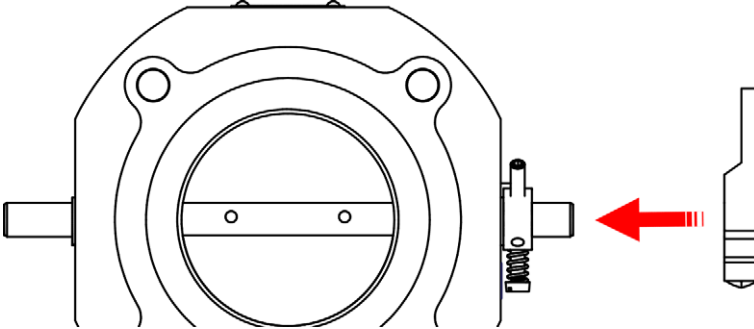

3. Tighten the attachment screw on the operating lever slightly.
  - ▶ The throttle can be moved carefully by hand using the MOTORTECH operating lever.
  - ▶ You can align the operating lever and install the connecting rod (see section *Aligning and Connecting the Operating Lever* on page 15).

## 5.5 Aligning and Connecting the Operating Lever

### Aligning the Operating Lever on the Stepper Motor

1. Loosen the M8 screw on the operating lever on the stepper motor.
2. Put the operating lever on the stepper motor into the position shown.

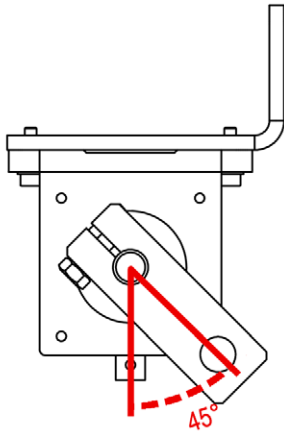

3. Tighten the M8 screw on the operating lever *slightly* to ensure the lever remains in the position set.
  - ▶ The operating lever on the stepper motor is provisionally fixed in place.

### Installing the Connecting Rod on the Operating Lever of the Stepper Motor

Screw on the connecting rod to the operating lever on the *stepper motor* (torque 15 Nm / 11 lb-ft).

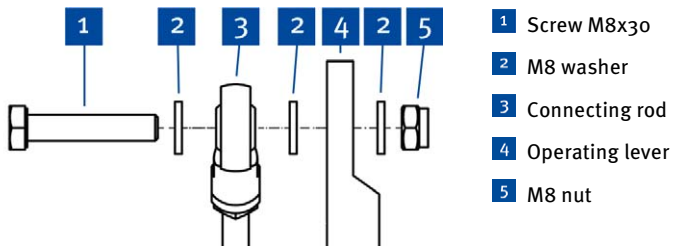

# 5 INSTALLATION

## Aligning the Operating Lever on the Throttle

1. Move the throttle *to its limit* in the *closed* position.  
The position of the throttle can be recognized by the alignment of the groove in the shaft.

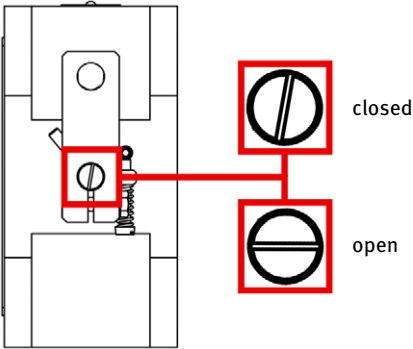

2. Loosen the M8 screw on the operating lever of the throttle, without at the same time changing the throttle position.
3. Set the operating lever on the throttle parallel to the operating lever on the stepper motor, without at the same time changing the throttle position.

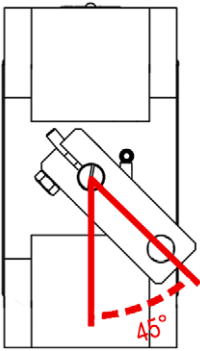

4. Screw the connecting rod (as with the operating lever on the stepper motor) to the operating lever on the throttle (torque 15 Nm / 11 lb-ft).
5. Tighten the M8 screw on the operating lever on the throttle (torque 15 Nm / 11 lb-ft).
  - ▶ The operating levers of throttle and stepper motor are parallel to each other and connected via the connecting rod.
  - ▶ You can start up the throttle gear (see chapter *Start-Up* on page 17).



## 6 START-UP

Start up the throttle gear as follows:  
(Also read the operating manual of the VariStep stepper motor card).



### Risk of damage!

Throttle gear, stepper motor card and engine can be damaged by improper handling of the stepper motor card. Read and understand the operating manual of the stepper motor card.

1. Loosen the attachment screw of the operating lever on the stepper motor. (Do not loosen the screw for fixing the connecting rod!)
2. Make sure that the throttle is completely closed (see section *Aligning and Connecting the Operating Lever* on page 15).



### Risk of damage!

The throttle must be closed completely. Otherwise the fuel supply to the engine cannot be completely interrupted during operation.

3. Switch the VariStep stepper motor card to manual mode.
4. Connect the stepper motor card to the supply voltage.



### Risk of damage!

If the stepper motor is incorrectly configured, the throttle cannot open and close properly. This can lead to engine damage.

5. Load the right configuration into the stepper motor card with the MICT:
  - Device type: *Throttle*
  - Throttle: *TG clockwise*
  - All other settings depend on the speed adjustment or master control.

## 6 START-UP

6. Perform a reference run.



**Do not move drive shaft!**

If you move the drive shaft of the stepper motor after the reference run, you must perform a new reference run.

7. Tighten the attachment screw of the operating lever on the stepper motor (15 Nm / 11 lb-ft), without at the same time changing the alignment of the operating levers.
  - ▶ The throttle gear is operational.

## 7 ERRORS

### Troubleshooting

Problem	Possible cause	Solution
Throttle movement is delayed.	Attachment screw of an operating lever has loosened.	Make sure that all screws are tight enough. Perform a reference run after this.
Throttle does not move.	Throttle is soiled.	Clean the throttle. After this, check that the system is tight!
	Influence of master control	Check the master control.
	Stepper motor is defective.	Replace the stepper motor.
	Stepper motor card is in error mode.	Confirm all error messages.
	Stepper motor card is incorrectly configured.	Configure the stepper motor card. Perform a reference run after this.
	Wiring of stepper motor and/or stepper motor card is defective.	Check the wiring and make sure that the supply voltage is available.
Throttle does not open/close completely.	Attachment screw of an operating lever has loosened.	Make sure that all screws are tightened. Perform a reference run after this.
	Operating levers are incorrectly aligned.	Align the operating levers correctly. Perform a reference run after this.
Throttle does not open/close completely.	Stepper motor card is incorrectly configured.	Configure the stepper motor card. Perform a reference run after this.
	Stepper motor does not move uninterrupted.	There is <b>no</b> defect. If the right quantity of gas is supplied, the motor stays in its position.

# 8 MAINTENANCE

## 8.1 Customer Service Information

You can reach our customer service during business hours at the following phone and fax number, or by e-mail:

Phone: +49 5141 93 99 0  
Fax: +49 5141 93 99 99  
Email: [service@motortech.de](mailto:service@motortech.de)

## 8.2 Returning Equipment for Repair / Inspection

Get a return form and return number from MOTORTECH to return the device for repair and inspection.

Fill out the return form completely. The completely filled out return form guarantees fast, smooth processing of the repair order.

Send the device and the return form to one of the two addresses below or to the nearest MOTORTECH representative:

### MOTORTECH GmbH

Hogrevestr. 21-23  
29223 Celle  
Germany  
Phone: +49 5141 93 99 0  
Fax: +49 5141 93 99 98  
[www.motortech.de](http://www.motortech.de)  
[motortech@motortech.de](mailto:motortech@motortech.de)

### MOTORTECH Americas, LLC

1400 Dealers Avenue, Suite A  
New Orleans, LA 70123  
USA  
Phone: +1 504 355 4212  
Fax: +1 504 355 4217  
[www.motortechamericas.com](http://www.motortechamericas.com)  
[info@motortechamericas.com](mailto:info@motortechamericas.com)

## 8.3 Instructions for Packaging the Equipment

For return shipment, equipment should be packaged as follows:

- Use packaging material that does not damage the equipment surfaces.
- Wrap the equipment with sturdy materials and stabilize it inside the packaging.
- Use sturdy adhesive film to seal the packaging.

## 8.4 Spare Parts and Accessories

For spare parts and accessories, please refer to our current Product Guide, which is available for you to download on the Internet at [www.motortech.de](http://www.motortech.de).



## Original MOTORTECH Accessories for Stationary Gas Engines

As a supplier, MOTORTECH develops, produces and distributes accessories as well as spare and wearing parts for nearly all kinds of stationary gas engines worldwide: Ignition control and monitoring, industrial spark plugs and high tension leads, wiring systems and gas regulation– from detonation to speed control and complete gas engine management. On-site support and special training courses complete our service.



### **MOTORTECH GmbH**

Hogrevestr. 21-23  
29223 Celle  
Germany  
Phone: +49 5141 93 99 0  
Fax: +49 5141 93 99 99  
[www.motortech.de](http://www.motortech.de)  
[motortech@motortech.de](mailto:motortech@motortech.de)

### **MOTORTECH Americas, LLC**

1400 Dealers Avenue, Suite A  
New Orleans, LA 70123  
USA  
Phone: +1 504 355 4212  
Fax: +1 504 355 4217  
[www.motortechamericas.com](http://www.motortechamericas.com)  
[info@motortechamericas.com](mailto:info@motortechamericas.com)