

Throttle Bodies with Integrated Stepper Motor

P/N 30.42.100-D, P/N 30.42.100-D-HT

Variants

- standard diameters D of the throttle (*see drawing*) 60 mm (2.36"), 68 mm (2.68")
- possible diameters of the throttle 48 mm (1.89") to 68 mm (2.68")

Dimensions

- length/width of mounting flange 113 mm (4.45")
- hole spacing on the mounting flange 75 mm (2.95")
- height of mounting flange 61 mm (2.40")
- length including stepper motor 269.8 mm (10.62") (*standard version*)
295 mm (11.61") (*HT version*)
- width of stepper motor 56.4 mm (2.22")

Connections

- stepper motor 10-pole military connector

Weight

- P/N 30.42.100-60 2.6 kg (5.73 lbs)
- P/N 30.42.100-68 2.5 kg (5.51 lbs)
- P/N 30.42.100-60-HT 2.7 kg (5.95 lbs)
- P/N 30.42.100-68-HT 2.6 kg (5.73 lbs)

Mechanical Data

- permissible vibrations 5g at 20 to 2000 Hz
- maximum rotation angle of the throttle 80°
- chemical resistance water, oil, gaseous fuels
- maximum pressure 6 bar (87 psi)
- maximum temperature of the medium flowing through 125 °C (257 °F) (*standard version*)
200 °C (392 °F) (*HT version*)

Climatic Environmental Conditions

- permissible temperature range -20 °C to +85 °C (-4 °F to +185 °F)
- maximum relative humidity 95%

Characteristics of Stepper Motor

- resolution 0.05625°
- speed (when opening 80°) 170 ms
- holding torque 1.4 Nm (1.03 lb-ft)

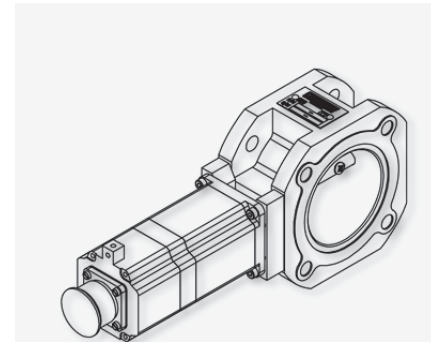

Overview Drawings

P/N 30.42.100-D

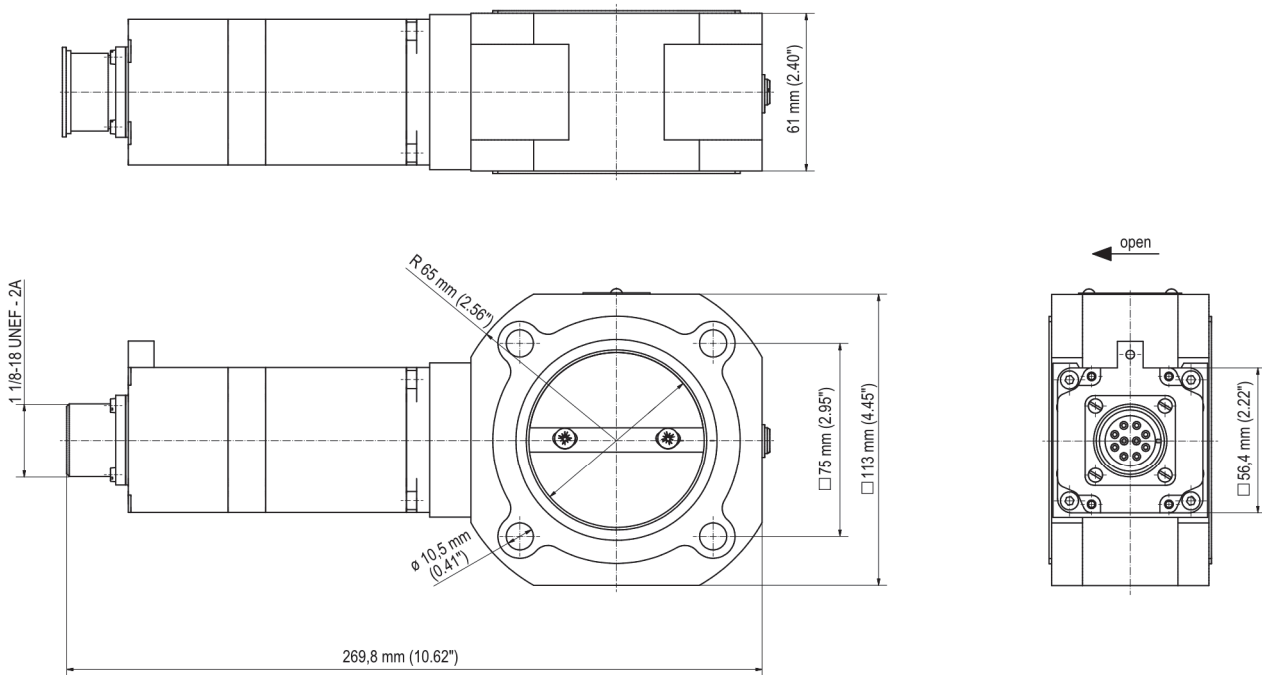

P/N 30.42.100-D-HT

